

SD25

VERTICAL FEED MIXERS SINGLE AUGER SD25

About Product

At our production line SD25 is the smallest wheeled machine. With its chassis and design, we can mention that it is a high-level machine in use and benefit. It functions perfectly in terms of homogeneity, helix, and blade structure, which result in increasing productivity.

Optional Features

- ▶ Electric Motor 7.5 Kw 1500 Rpm
- ▶ Loading Bucket
- ▶ Weight System

| STANDARD FEATURES | |
|--------------------------|-------------------|
| CAPACITY | 2.5m ³ |
| MIXING SYSTEM | Single Auger |
| NUMBER OF BLADES | 10 |
| MIN. POWER REQUIREMENT | 10 HP |
| PTO TRANSFER | 540 Rpm |
| TRANSMISSION TYPE | Planet |
| AUGER SPEED | 54 Rpm |
| WHEEL SIZE | 10x80x12 |
| LOADING BUCKET CAPACITY | 100 Kg |
| FEED DISCHARGE DIRECTION | Standard (Right) |
| JACK | Mechanic |
| CONVEYOR BELT | Optional |
| JAMMING AX | Manuel |
| EXCHANGE RATIOS | 10 |

| STANDARD FEATURES | |
|-------------------|---------|
| LENGTH | 3590 mm |
| HEIGHT | 1870 mm |
| WIDTH | 1730 mm |
| BODY SHEET | 6 mm |
| BASE PLATE | 15 mm |
| EMPTY WEIGHT | 1030 kg |
| FULL WEIGHT | 1650 kg |

Depending on added options, the specified features can be change.

| CAPACITY | MINIMUM POWER | AUGER SPEED | NUMBER OF BLADES |
|-------------------------|---------------|--------------|------------------|
| 2,5m³ | 10hp | 54Rpm | 10 |

Pto speed 540 rpm / calculated according minute.

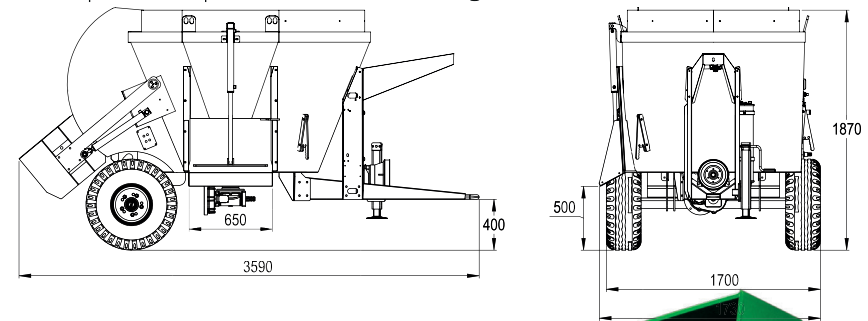

VERTICAL FEED MIXERS